



-EVE PowerCO.,LTD Confidential Proprietary-

Model	LF280K	Specification No	PBRI-LF280K-D06-01	Version	C
-------	--------	------------------	--------------------	---------	---

Product Specification

Prismatic LFP Cell

Model:LF280K

: LF280K

Drafted by	Product Design Checked by	Quality Checked by	Sales Checked by	Approved by
Hongbo Liu 刘红波	Aluohang 王峰	李明	黄景	花丁丁

Customer Recipient
Company Name
Approved by :
Date :

June 2023

EVE Power Co.,Ltd.

Model	LF280K	Specification No	PBRI-LF280K-D06-01	Version	C
-------	--------	------------------	--------------------	---------	---

Customer Requirements

Customers shall communicate and reach an agreement with EVE Power Co.,Ltd.regarding special requirements beyond the product specifications.If certain applications and operation conditions are out of the description of this specification,EVE may design and manufacture products according to customer's special requirements.

No	Special Requirements	Standards
1		
2		
3		
4		
5		

Customer Code: ____ **Signature :** ____ **Date :**



-EVE PowerCO,LTD Confidential Proprietary-

Model	LF280K	Specification No	PBRI-LF280K-D06-01	Version	C
-------	--------	------------------	--------------------	---------	---

Revision History

Version	Date	Contents	Checked By
A	2022.4.1	First issue	Yong Zhang
B	2023.2.10	1、 Revised the rate charge (discharge)performance,charge(discharge) performance at different temperatures and other performance parameters refer to GB/T 36276-2018 2、 Added the English version 3、 Updated the specification number according to the newest coding rules	Yong Zhang
C	2023.6.6	Adjusted chapter content according to the latest EVE specification template EVE,	Hongbo Liu



Model]	LF280K	Specification No	PBRI-LF280K-D06-01	Version	C
--------	--------	------------------	--------------------	---------	---

Contents

CUSTOMER REQUIREMENTS

REVISION HISTORY !

TERM DEFINITION v

1 FUNDAMENTAL INFORMATION 1-

1.1 Scope of Application 1-

1.2 Product Type 1-

1.3 Product Model 1-

2 CELL SPECIFICATIONS AND PARAMETERS 1-

2.1 Basic Specifications and Parameters 1-

2.2 Electrical Performance Parameters 2-

2.3 Safety Performance Parameters 3-

2.4 Cell Drawing 4-

2.5 Appearance 4-

3 TEST CONDITIONS AND METHODS 4-

3.1 Environmental Conditions 4-

3.2 Measuring Instruments 4-

3.3 Test Clamp Preparation and Installation 4-

3.4 Dimensions 6-

3.5 Weight 6-

3.6 Internal Resistance 6-

3.7 Pretreatment 7-

3.8 Charge Calibration 7-

3.9 Discharge Calibration 7-

3.10 Capacity and Energy Calibration 8-

3.11 Rate Discharge Performance 8-

3.12 High/Low Temperature Discharge Performance / 9-

3.13 Capacity Retention and Capacity Recovery 10-

3.14 Storage 10-

3.15 Cycle life 11-

3.16 Swelling Force Test 13-

3.17 Safety Performance 13

Model	LF280K	Specification No	PBRI-LF280K-D06-01	Version	C
-------	--------	------------------	--------------------	---------	---

4 CBL APPLICATION INSTRUCTIONS..... 17

4.1 Welding parameters recommendation 17-

4.2 Charge and Discharge Parameters 17-

4.3 Safety Limits 20-

4.4 Parameters Recommendation for Module Design24-

4.5 Thermodynamic Parameters 25-

5 PRECAUTIONS 26-

5.1 Product End-life Management26-

5.2 Long-term Storage 26-

5.3 Transportation and Handling Requirements 26-

5.4 Operation Precautions 27

5.5 Confidentiality agreement29-

5.6 Risk Warning29-

5.7 Disclaimer 30-

6 OTHERS 30-

6.1 Right and Obligations of EVE EVE.....30-

6.2 Right and Obligations of Customer31-

6.3 Language Conflict clause 31-

7 CONTACT INFORMATION 31-

APPENDIX: CEL DRAWING OF LF280K : LF280K 33-

Model	LF280K	Specification No	PBRI-LF280K-D06-01	Version	C
-------	--------	------------------	--------------------	---------	---

Term Definition

Product: Refers to the LF280K rechargeable lithium-ion cell with prismatic alu min-um shell manufactured by EVE Power Co.,Ltd.(hereinafter referred to as EVE)in this specification.

Customer: Refers to the buyer in the product sales contract signed with EVE.

Environment temperature: The ambient temperature where the cell is located.

Cell temperature: The temperature measured by temperature sensor installed at the center of cell surface.The selection of temperature sensor and measuring line shall be jointly agreed by EVE and the customer.

Fresh cell:Refers to cell within 7 days after production.

Power: The ratio of the charge/discharge power to the cell energy value measured multiple times by the battery system, denoted by P.For example,when the cell energy is 896Wh and the charge/discharge power is 448 W,the charge/discharge power is 0.5P;When the cell energy decays to 716.8Wh and the charge/discharge power is 358.4W,the charge/discharge ratio is 0.5P.

State of charge:Under unloaded conditions,the ratio of the cell capacity state to the nominal capacity measured in ampere-hour or watt-hour.The abbreviation is expressed by SOC.For example,if the capacity at 280 Ah is 100%SOC,then the capacity at 0 Ah is 0%SOC.

State of health:The ratio of actual cell capacity to nominal capacity,abbreviated as SOH.For example,if the cell capacity at 280 Ah is 100%SOH,when the cell capacity decays to 224 Ah,it's 80%SOH.

Cycle:A cycle means the cell being charged and discharged once according to the charging and discharging standards. The cell shall be charged and discharged once according to the specified charging and discharging standards as a cycle.The cycle includes short-term normal charging or a combination of regenerative charging and discharging processes.In the charging process,sometimes there is only normal charging and no regenerative charging.The discharge can be formed by combining some partial discharges.

Model	LF280K	Specification No	PBRI-LF280K-D06-01	Version	C
-------	--------	------------------	--------------------	---------	---

Charge Calibration:The charging mode described in 3.8 of this specification.

Discharge Calibration:The discharging mode described in 3.9 of this specification.

Open circuit voltage:The voltage of the cell measured when unloaded or circuit is disconnected.The abbreviation is expressed by OCV

AC resistance:Apply 1kHz sine wave current between the positive and negative poles of the cell,and the internal resistance obtained is AC resistance,which is abbreviated as ACR.The test method is described in 3.6 of this specification

DC resistance:The ratio of the voltage changes to the corresponding current change under working conditions,and the abbreviation is DCR.The test method is as described in section 3.6 of this specification.

Module:The intermediate product between single cell and pack,which is formed by lithium-ion cells in series and parallel after installing cell monitors and management devices.

Pulse current:The currents that appear periodically are called pulse currents.The puke currents appear either in the same direction or in alternating positive and negative directions.

Compression force:When the module is assembled,the cell can withstand the force perpendicular to the cell stacking direction.

Swelling force: The force on the clamp due to cell expansion during use,which may be caused by inherent characteristic changes,such as the rebound electrode thickness.

Model	LF280K	Specification No	PBRI-LF280K-D06-01	Version	C
-------	--------	------------------	--------------------	---------	---

Units of measurement: Refer to following table

Table 1 Units of measurement

No.	Units	Abbreviation	Type of units
	Volt	V	Voltage
2	Ampere	A	Current
3	Ampere-Hour	Ah	Capacity
4	Watt-Hour	Wh	Energy
5	Ohm	Ω	Resistance
6	Milliohm	m Ω	Resistance
7	Degree Celsius	$^{\circ}\text{C}$	Temperature
8	Millimeter	mm	Length
9	Second	S	Time
10	Hertz	Hz	Frequency
11	Newton	N	Force
12	Kilogram-Force	kgf	Force

Model	LF280K	Specification No	PBRI-LF280K-D06-01	Version	C
-------	--------	------------------	--------------------	---------	---

1 Fundamental Information

1.1 Scope of Application

This document describes the specification of the LF280K lithium-ion cell manufactured by EVE Power Co.,Ltd. EVELF280K

1.2 Product Type

Prismatic lithium-ion cell with aluminum shell

1.3 Product Model:LF280K

2 Cell Specifications and Parameters

2.1 Basic Specifications and Parameters

Table 2 Basic specifications and parameters

Items	Specifications	Remarks
Nominal Capacity	280 Ah	0.5P/0.5P,25°C±2°C,2.5 V~3.65 V Fresh cell
Nominal Energy	896 Wh	
Nominal Voltage	3.2 V	0.5P discharge,25°C±2°C,2.5 V~3.65 V 0.5P, 25°C±2°C,2.5V~3.65 V
Charging Cut-off Voltage (U _{max})	3.65 V	/
Discharging Cut-off Voltage (U _{min})	2.5 V(T>0°C) 2.0 V(T≤0°C)	/
Standard Charging Power	448 W	25°C±2°C,0.5P
Max Continuous Charging Power	896 W	25°C±2°C,1P
Standard Discharging Power	448 W	0.5P
Max.Continuous Discharging Power	896 W	25°C±2°C,1P



Model		Specification No.		Version	
	LF280K		PBRI-LF280K-D06-01		C
Initial Internal Resistance		$\leq 0.25 \text{ m}\Omega$	AC,1 kHz,Delivery SOC Fresh cell		
Direct Current Resistance (DCR)		$\leq 1.5 \text{ m}\Omega$	25°C,50%SOC,1C,10s, Fresh cell		
Weight		5490 g \pm 300 g	/		
Dimensions (With insulation film)	Height1 1(H1)	207.2 \pm 0.5 mm	With Terminal		
	Height2 (H2)	204.6 \pm 0.5 mm	Without Terminal		
	Length(L)	173.7 \pm 0.5 mm	/		
	Thickness(T)	71.7 \pm 0.8 mm	(300 kgf \pm 20 kgf compression force, Delivery SOC)		
	Center distance between the poles(D)	123.0 \pm 0.3 mm	/		
Operation Temperature	Charging Temperature	0~60°C	/		
	Discharging Temperature	-30~60°C	/		
Storage Temperature	1 year	0~35°C	Delivery SOC status		
	1 month	-20~45°C			
Swelling Force		$\leq 40000 \text{ N}$	70%SOH		
		$\leq 50000 \text{ N}$	60%SOH		

2.2 Electrical Performance Parameters

Table 3 Electrical performance parameters

3

Items	Specifications			Testing Methods
Rate Charge and Discharge Performance	Items	Discharging energy	Energy efficiency	3.11
	Rate	E ₁ *	E ₁ */E ₁ \geq 93.5%	
	0.5P			



-EVE Power CO,LTD Confidential Proprietary-

Model	LF280K	Specification No.	PBRI-LF280K-D06-01		Version	C	
		1P	$E_2^4 \geq 95\% * E_1^*$	$E_3^*/E_3 \geq 87\%$			
High/Low Temperature Charge/Discharge Performance /		Items	Discharging energy	Energy efficiency	3.12		
	Temp						
	45°C		$E_4^4 \geq 98\% * E_0^*$	$E_4^*/E_4 \geq 93\%$			
	5°C		$E_5^4 \geq 80\% * E_0^*$	$E_5^*/E_5 \geq 76\%$			
The Capacity Retention and Recovery (100%SOC)		Items	Discharging energy retention	Discharging energy recovery	3.13		
	Temp						
	25°C & 28 days		$E_6^* \geq 95\% * E_0^*$	$E_7^* \geq 97\% * E_0^*$			
	45°C & 7 days		$E_g^* \geq 95\% * E_0^*$	$E_g^* \geq 97\% * E_0^*$			
Storage (50%SOC)		Items	Discharging energy recovery		3.14		
	Temp						
	25°C & 28days		$\geq 98\% * E_0^*$				
	45°C & 28days		$\geq 97\% * E_0^*$				
Cycle Life	25°C Cycle		8000 cycles, 70%SOH		3.15		
	45°C Cycle		3000 cycles, 70%SOH				

2.3 Safety Performance Parameters

Table 4 Safety performance parameters

Items	Specifications	Test Methods
Over-charge	No fire, No explosion	3.17.1
Over-discharge	No fire, No explosion	3.17.2
External Short-circuit	No fire, No explosion	3.17.3
Crush Test	No fire, No explosion	3.17.4
Drop Test	No fire, No explosion	3.17.5
Low Pressure	No leakage, No fire, No explosion	3.17.6
Heating	No fire, No explosion	3.17.7
Thermal Runaway	No fire, No explosion	3.17.8

Model	LF280K	Specification No.	PBRI-LF280K-D06-01	Version	C
-------	--------	-------------------	--------------------	---------	---

2.4 Cell Drawing

See Appendix

2.5 Appearance

The cell shall not have any defects that may affect their commercial values,including obvious scratches,cracks,rust stains,discoloration,or electrolyte leakage.

3 Test Conditions and Methods

3.1 Environmental Conditions

Unless otherwise specified,the test should be carried out in an environmental temperature of $25^{\circ}\text{C}\pm 2^{\circ}\text{C}$,relative humidity of 10%~90%,and atmospheric pressure of 86 kPa to 106 kPa.The room temperature mentioned in this specification refers to $25^{\circ}\text{C}\pm 2^{\circ}\text{C}$.

3.2 Measuring Instruments

The accuracy of measuring device should meet the following requirements:

A.Voltage measuring device : $\pm 0.05\%$ FS;

B.Current measuring device : $\pm 0.05\%$ FS;

C.Temperature measuring device : $\pm 1^{\circ}\text{C}$;

D.Dimension measuring device : $\pm 0.01\text{ mm}$;

E.Weight measuring device : $\pm 0.1\text{ g}$.

Note:During the testing process,voltage,current,ambient temperature,and cell temperature must be recorded.It is recommended to collect the cell temperature at the terminal and the center of large surface (or side).

3.3 Test Clamp Preparation and Installation

3.3.1 Ordinary Steel Clamp

The single cell shall be clamped with steel splints(thickness:10 mm).The splints need to cover the large surfaces of the cell and be fixed with 6 M8 bolts.All sides of the splints need to be covered with insulating film Clamp as shown below:

Model	LF280K	Specification No.	PBRI-LF280K-D06-01	Version	C
-------	--------	-------------------	--------------------	---------	---



Fig.1 Diagram of the clamp



Fig.2 Diagram of the clamp covered with insulation film 2

Place the cell (15%~40%SOC) which is covered with blue film (material:PET, thickness:0.1 mm) and top film (material:PC, thickness:0.3 mm) in the middle of the splint, fix the clamp with 6 M8 bolts to ensure that the initial compression force on the cell is $300 \text{ kgf} \pm 20 \text{ kgf}$. Then use a micro meter to measure the thickness of the cell (at upper, middle and lower) with splints, and the thickness tolerance shall be controlled within 0.3 mm.



Fig.3 Diagram of cell filming



Fig.4 Diagram of cell with clamp

3.3.2 Swelling Force Clamp

Place the cell (15%~40%SOC) which is covered with blue film (material:PET, thickness:0.1 mm) and top film (material:PC, thickness:0.3 mm) in the middle of the splint, and adjust the swelling force clamp pre-tensioning device until the initial compression force is $(300 \text{ kgf} \pm 20 \text{ kgf})$. Then use a micrometer to measure the thickness of the cell (at upper, middle and lower) with splints, and the thickness tolerance shall be controlled within 0.3 mm.

Model	LF280K	Specification No.	PBRI-LF280K-D06-01	Version	C
-------	--------	-------------------	--------------------	---------	---

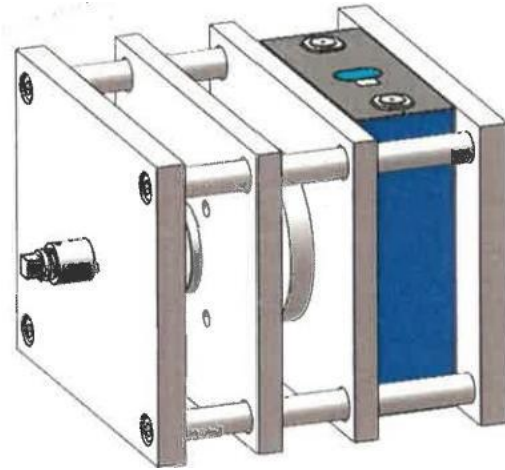

Fig.5 Diagram of cell with a swelling force clamp

3.4 Dimensions

Test instrument:Automatic wrapping machine;

Test method:Use the wrapping machine to measure the length,width and height of the cell.And apply a

300 kgf±20 kgf force on it.

The thickness of the cell will increase as the SOC increases as well as with the using time.The thickness here indicates the thickness of the cell at the time of delivery.

3.5 Weight

Test instrument:electronic scale;

Test method:measure the weight of the cell by electronic scale.

3.6 Internal Resistance

a. ACR:test the cell at delivery SOC with 1kHz sine wave current at room temperature.

b. DCR:Charge the cell to 3.65 V with constant current of 0.5C,and then charge at constant voltage of 3.65 V until the current decreases to 0.05C.Rest for 30 min,and discharge with constant current of 0.5C for 60 min afterwards (adjust the SOC to 50%).Then rest for 1 h,and record the voltage V_1 at the end of the period.Discharge the cell with a constant current of 1C for 10 seconds and record the voltage V_2 at the end of the pulse,and calculate the DCR., $DCR=(V_1 - V_2) \times 1000 / 280.0(m(2))$.



Model	LF280K	Specification No	PBRI-LF280K-D06-01	Version	C
-------	--------	------------------	--------------------	---------	---

3.7 Pretreatment

Before the formal test,pretreat the cell to ensure it is activated and stable.The steps are as follows:

- a.Charge the cell according to the standard charging mode;
- b.Discharge the cell according to the standard discharging mode;
- c.Repeat a~b no more than 5 times;

If the discharge capacity of the cell changes no more than 3%of the nominal capacity for two consecutive times,it is considered that the cell has completed the pretreatment,and the pretreatment cycle can be terminated.

3.8 Charge Calibration

At the ambient temperature of $25^{\circ}\text{C}\pm 2^{\circ}\text{C}$,rest for 5h;
Discharge at a constant powerof448 W to 2.5 V and rest for 30 min;
Charge at a constant powerof448 W to 3.65 V,and rest for 30 min.

3.9 Discharge Calibration

At the ambient temperature of $25^{\circ}\text{C}\pm 2^{\circ}\text{C}$,rest for 5h;
Charge at a constant power of 448W to 3.65 V,and rest for 30 min;
Discharge at a constant power of 448W to 2.5 V,and rest for 30 min.

3.10 Capacity and Energy Calibration

Capacity calibration is to discharge the cell according to (3.9)at the ambient temperature of $25\pm 2^{\circ}\text{C}$.Charge the cell at a constant power of 448 W to 3.65 V and rest for 30 min.Discharge the cell at a constant power of 448 W to 2.5V and rest for 30 min.Repeat 5 times and record the average of the last three charging energy as E_0 ,the average of the last three discharging energy as E_0 and the average of the last three discharging capacity as C_0^* .

Model	LF280K	Specification No	PBRI-LF280K-D06-01	Version	C
--------------	--------	-------------------------	--------------------	----------------	---

3.11 Rate Discharge Performance

Discharge the cell according to (3.9) at the ambient temperature of $25^{\circ}\text{C} \pm 2^{\circ}\text{C}$;

Charge the cell to 3.65 V at a constant power of 448 W and rest for 30 min, note as E_1^* ;

Discharge to 2.5 V at a constant power of 448 W and rest for 30 min, note as E_1^* ;

Charge the cell to 3.65 V at a constant power of 896 W and rest for 30 min, note as E_2 ;

Charge the cell to 3.65 V at a constant power of 448 W and rest for 30 min;

Discharge to 2.5 V at a constant power of 896 W and rest for 30 min, note as E_2^* ;

Discharge the cell to 2.5 V at a constant power of 448 W and rest for 30 min;

Charge the cell to 3.65 V at a constant power of 896 W and rest for 30 min, note as E_3 ;

Discharge to 2.5 V at a constant power of 896 W and rest for 30 min, note as E_3^* ;

Discharge to 2.5 V at a constant power of 448 W and rest for 30 min;

1P discharge energy retention rate $= E_2/E_1^*$

0.5P energy efficiency $= E_1^*/E_1$;

1P energy efficiency $= E_3^*/E_3$.

448 W 3.65 V, 30 min, E_1 ;

448 W 2.5 V, 30 min, E_1 ;

896 W 3.65 V, 30 min, E_2 ;

448 W 3.65 V, 30 min;

896 W 2.5 V, 30 min, E_2^* ;

448 W 2.5 V, 30 min;

$1P = E_2^*/E_1^* \times 100\%$;

$0.5P = E_1/E_1^* \times 100\%$;

$1P = E_3^*/E_3 \times 100\%$;

3.12 High/Low Temperature Discharge Performance

3.12.1 45°C Charge-discharge Performance

Discharge the cell according to (3.9) at the ambient temperature of $25^{\circ}\text{C} \pm 2^{\circ}\text{C}$;

Rest the cell for 5 h under the ambient temperature of $45^{\circ}\text{C} \pm 2^{\circ}\text{C}$;

Charge to 3.65 V at a constant power of 448 W and then rest for 30 min, note the energy as E_4 ;

Discharge to 2.5 V at a constant power of 448 W and rest for 30 min, note the energy as E_4^* ;

Discharge energy retention rate $= E_4^*/E_4 \times 100\%$, energy efficiency $= E_4^*/E_4 \times 100\%$.

Model	LF280K	Specification No	PBRI-LF280K-D06-01	Version	C
-------	--------	------------------	--------------------	---------	---

3.12.2 5°C Charge-discharge Performance

Discharge the cell according to (3.9)at the ambient temperature of 25°C ±2°C;

Rest the cell for 5 h at the ambient temperature of 5°C ±2°C;

Charge to 3.65 V at a constant powerof448 W and then rest for 30 min,note the energy as Es;

Discharge to 2.5 V at a constant powerof448 W and rest for 30 min,note the energy as Es*;

Discharge energy retention rate =Es*/Eo*100%,energy efficiency =Es*/EsX100%.

3.13 Capacity Retention and Capacity Recovery

3.13.1 25°C Capacity Retention and Capacity Recovery

Charge the cell according to (3.8)at the ambient temperature of 25°C ±2°C;

Store the cell for 28 days at the ambient temperature of 25°C ±2°C;

Discharge to 2.5 V at a constant powerof448 W and rest for 30 min,note the energy as Es*;

Charge to 3.65 V at a constant powerof448 W and rest for 30 min,note as Es;

Discharge to 2.5 V at a constant power of 448 W and rest for 30 min,note the energy as Er*;

Discharge energy retention rate =E₆*/E_o*100%;Discharge energy recovery rate =E₇*/E_o*100%.

3.13.2 45°C Capacity Retention and Capacity Recovery

Charge the cell according to (3.8)at the ambient temperature of 25°C ±2°C;

Store the cell for 7 days at45°C±2°C and rest for 5 h at 25°C ±2°C;

Discharge to 2.5 V at a constant powerof448 W and rest for 30 min,note the energy as Es*;

Charge to 3.65 V at a constant powerof448 W and rest for 30 min,note the energy as E₇;

Discharge to 2.5 V at a constant powerof448 W and rest for 30 min,note the energy as E₉;

Discharge energy retention rate =E*/E_o*100%; Discharge energy recovery rate =E_g*/E_o*100%.

3.14 Storage

3.14.1 25°C Storage

Charge the cell according to (3.8)at 25°C ±2°C;

Discharge for 60 min at a constant powerof448 W and rest for 30 min;

Model	LF280K	Specification No	PBRI-LF280K-D06-01	Version	C
-------	--------	------------------	--------------------	---------	---

Store the cell for 28 days at $25^{\circ}\text{C}\pm 2^{\circ}\text{C}$ and rest for 5 h at $25^{\circ}\text{C}\pm 2^{\circ}\text{C}$;
 Discharge to 2.5 V at a constant power of 448W and rest for 30 min;
 Charge to 3.65 V at a constant power of 448W and rest for 30 min,note the energy as E_g ;
 Discharge to 2.5 V at a constant power of 448W and rest for 30 min,note the energy as E_o^* ;
 Charge energy recovery rate $=E_g/E_o^*\cdot 100\%$; discharge energy recovery rate $=E_{i0}^*/E^*\cdot 100\%$.

3.14.2 45°C Storage

Charge the cell according to (3.8)at the ambient temperature of $25^{\circ}\text{C}\pm 2^{\circ}\text{C}$;
 Discharge for 60 min at a constant powerof448 W and rest for 30 min;

Store the cell for 28 days at the ambient temperature of $45^{\circ}\text{C}\pm 2^{\circ}\text{C}$ and rest for 5 h at the ambient temperature of $25^{\circ}\text{C}\pm 2^{\circ}\text{C}$;

Discharge to 2.5 V at a constant powerof448 W and rest for 30 min;
 Charge to 3.65 V at a constant powerof448 W and rest for 30 min;
 Discharge to 2.5 V at a constant powerof448 W and rest for 30 min,note the energyas E_{10}^* ;
 Discharge energy recovery rate $=E_{10}^*/E_o^*\cdot 100\%$.

3.15 Cycle life

3.15.1 25°C Cycle

Before the test,prepare and install the clamp according to 3.3.1

Pre-cycle initial capacity test:test the cell energy according to (3.10).

Cycle test:at ambient temperature of $25^{\circ}\text{C}\pm 2^{\circ}\text{C}$;

- a. Discharge the cell in accordance with (3.9);
 - b.Charge the cell to 3.65 V at a constant power of 448 W and rest for 30 minutes;
 - c.Discharge to 2.5 V at a constant powerof448 W and rest for 30 minutes;
 - d.Repeat steps b~c6000 times.
- b. 448 W 3.65 V, 30 min;
 - c. 448 W 2.5 V, 30 min;
 - d. b~c 6000cycle

Capacity test after cycling at ambient temperature of $25^{\circ}\text{C}\pm 2^{\circ}\text{C}$:

Model	LF280K	Specification No	PBRI-LF280K-D06-01	Version	C
-------	--------	------------------	--------------------	---------	---

Charge the cell to 3.65 V at a constant power of 0.5P,rest for 30 min;Discharge to 2.5 V at a constant power of 0.5P,rest for 30 min;Charge the cell to 3.65 V at a constant powerof0.5P,restfor 30 min;Discharge to 2.5 V at a constant power of 0.5P,record the discharge capacity C_i .rest for 30 min;The capacity retention rate $=C_i^*/280Ah \times 100\%$.

When the cell is at 80%SOH and 70%SOH,modify the charging and discharging power according to the capacity of the cell:100~80%SOH,448 W;80~70%SOH;358.4 W;70~60%SOH,313.6 W.

3.15.2 45°C Cycle

Before the test,prepare and install the clamp according to 3.3.1.
3.3.1

Pre-cycle initial capacity test:test the cell capacity according to (3.10).

Cycle test:at ambient temperature of $45^\circ C \pm 2^\circ C$;

a.Discharge the cell in accordance with (3.9);

b.Charge the cell to 3.65 V at a constant power of 448 W and rest for 30 minutes;

c.Discharge to 2.5 V at a constant powerof448 W and rest for 30 minutes;

d.Repeat steps b~c 2500 times.

b.448 W 3.65 V, 30 min;

c. 448 W 2.5 V, 30 min;

d. b~c 2500cycle。

Capacity test after cycle at ambient temperature of $25^\circ C \pm 2^\circ C$:

Charge the cell to 3.65 V at a constant power of 0.5P,rest for 30 min;Discharge to 2.5 V at a constant power of 0.5P,rest for 30 min;Charge the cell to 3.65 V at a constant power of 0.5P,rest for 30 min;Discharge to 2.5 V at a constant power of 0.5P,record the discharge capacity C_{rz} and rest for 30 min;The capacity retention rate $=C_{iz}^*/280Ah \times 100\%$.

When the cell is at 80%SOH and 70%SOH,modify the charging and discharging power according to the capacity of the cell:100~80%SOH,448 W;80~70%SOH;358.4 W;70~60%SOH,313.6 W.

Model	LF280K	Specification No	PBRI-LF280K-D06-0	Version	C
-------	--------	------------------	-------------------	---------	---

3.16 Swelling Force Test

Prepare and install the clamp according to 3.3.2.before the test.

Cycle according to (3.15.1)and record cell swelling force and discharge capacity retention rate during test process. (3.15.1)

3.17 Safety Performance

3.17.1 Over-charge Test

Charge the cell according to (3.8)at the ambient temperature of $25^{\circ}\text{C}\pm 2^{\circ}\text{C}$,and install the test clamp according to the methods in(3.3.1).Charge the cell to 5.475 V at a constant current of 280 A or for 1 hour,and then stop charging.

Observe for 1 hour.(Refer to GB/T 36276-2018 Lithium ion battery for electrical energy storage)

3.17.2 Over-discharge Test

Charge the cell according to (3.8)at the ambient temperature of $25^{\circ}\text{C}\pm 2^{\circ}\text{C}$,and install the test clamp according to the methods in(3.3.1).Discharge the cell to 0 V at a constant current of 280 A or for 90 min,and then stop discharging. Observe for 1 hour.Refer to GB/T 36276-2018 Lithium ion battery for electrical energy storage)

3.17.3 External Short-circuit Test

Charge the cell according to(3.8)at the ambient temperature of $25^{\circ}\text{C}\pm 2^{\circ}\text{C}$,and install the test clamp according to the methods in(3.3.1).Short-circuit the positive and negative terminals of the cell externally for 10 min,and the resistance value of the external circuit shall be less than 5 m Ω .Observe for 1h.(Refer to GB/T 36276-2018 Lithium ion battery for electrical energy storage)

3.17.4 Crush Test

At the ambient temperature of $25^{\circ}\text{C}\pm 2^{\circ}\text{C}$,charge the cell according to(3.8).And carry out the test under the following conditions:

- a) Crush direction:apply pressure perpendicular to the direction of the cell plate;
- b) The form of the crush plate:a semi-cylinder with a radius of 75 mm,the length (L)of the semi-cylinder is greater than the size of the cell being crushed (refers to the figure below);

Model	LF280K	Specification No	PBRI-LF280K-D06-01	Version	C
-------	--------	------------------	---------------------------	---------	---

c) Crush speed:(5 ± 1)mm/s;

d) Crush degree:stop crushing when the voltage reaches 0V or the deformation reaches 30%or the crushing force reaches (13000 ± 780)N;keep it for 10 minutes.

Observe it for 1h. (Refer to GB/T 36276-2018 Lithium ion battery for electrical energy storage)

e)

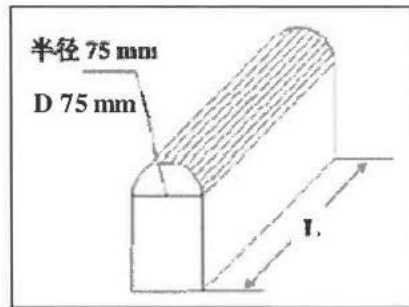

Fig.6 Diagram of the Extrusion Device

3.17.5 Drop Test

At the ambient temperature of $25^{\circ}\text{C}\pm 2^{\circ}\text{C}$,charge the cell according to (3.8).Drop the cell from a height of 1.5 meter to the concrete floor with its positive or negative terminals downwards.Then observe it for 1 hour.(Refer to GB/T 36276-2018 Lithium ion battery for electrical energy storage)

3.17.6 Low Pressure Test

At the ambient temperature of $25^{\circ}\text{C}\pm 2^{\circ}\text{C}$,charge the cell according to(3.8),and then install the test clamp according to(3.3.1).Put the cell into the low-pressure box,adjust the pressure to 11.6 kPa,keep the temperature at $25^{\circ}\text{C}\pm 2^{\circ}\text{C}$,and rest for 6 h.Then observe for 1 hour (Refer to GB/T 36276-2018 Lithium ion battery for electrical energy storage)

3.17.7 Heating Test(130°C)

At the ambient temperature of $25^{\circ}\text{C}\pm 2^{\circ}\text{C}$,charge the cell according to(3.8),and then install the test clamp according to(3.3.1).Put the cell into the temperature box,rise the temperature to $130^{\circ}\text{C}\pm 2^{\circ}\text{C}$ at a rate of $5^{\circ}\text{C}/\text{min}$,keep the temperature for 30 min and then stop heating.Observe for 1 hour (Refer to GB/T 36276-2018 Lithium ion battery for electrical energy storage)

Model	LF280K	Specification No	PBRI-LF280K-D06-01	Version	C
-------	--------	------------------	--------------------	---------	---

3.17.8 Thermal Runaway Test

(1)At the ambient temperature of $25^{\circ}\text{C}\pm 2^{\circ}\text{C}$,charge the cell according to(3.8),and then install the test clamp according to (3.3.1)

(2)Use a flat or rod-shaped heating device,and its surface should be covered with ceramic,metal or insulating layer.The heating power of the heating device should be in the range of 600~1200 W.Complete the assembly of the cell and the heating device,the heating device should be in direct contact with the cell,and the size of the heating device should not be larger than the heated surface of the cell;Install a temperature monitor and the detection point temperature sensor is arranged on the far side of the principle heat conduction.That is,on the opposite side of the heating device.(see the picture below)The temperature data sampling interval should be shorter than 1 s,the accuracy should be $\pm 2^{\circ}\text{C}$,and the diameter of the temperature sensor tip should be less than 1 mm.

(3)After the cell is fully charged,continue to charge for 12 minutes at a constant current of 1C.

(4)Start the heating device and continue to heat the test object with its maximum power.When thermal runaway occurs or the temperature of the monitoring point reaches 300°C ,stop heating and turn off the heating device.

(5)Stop the test whenever fire or explosion occurs within or after the heating process for 1 h.

a)The test object generates a pressure drop;

b)The temperature of the monitoring point reaches the protection temperature of the cell;

c)Temperature rise rate of monitoring points $\geq 1^{\circ}\text{C}/\text{s}$.

When a)&c)or b)&c)occurs,it is determined that the cell is thermally out of control.(Refer to GB/T 36276-2018 Lithium ion battery for electrical energy storage)

Model	LF280K	Specification No	PBRI-LF280K-D06-01	Version	C
-------	--------	------------------	--------------------	---------	---

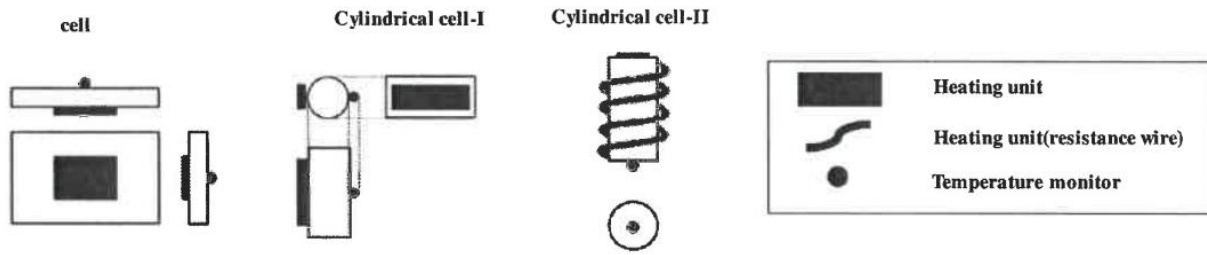

Fig.7 Schematic diagram of thermal runaway experiment

4 Cell Application Instructions

4.1 Welding parameters recommendation

Table 7 Welding Parameters Table

Items		Specifications	Remarks
Welding Parameter of Al Busbar	Laser Welding Depth	≤ 2.0 mm	/
	Max Pressure on Poles	700 N	Max force in longitudinal direction, no deformation.
	Max Torque on Poles	6 N·m	Max torsion, non- loosen
	Max Temperature on Poles	130°C	The maximum temperature that the pole bears before the plastic pad deforms.

4.2 Charge and Discharge Parameters

The following data is the reference performance data of LF280K Cell during BMS design. Actual use is subject to the using mode and conditions agreed by both parties.

4.2.1 Charging Mode

Table 8 Charging mode parameters table

Model	LF280K	Specification No	PBRI-LF280K-D06-01	Version	C
Parameters	Specifications		Conditions		
Standard charging power	0.5P	25°C±2°C			
Maximum continuous charging power	1P	25°C±2°C			
Standard charging voltage	Single cell≤3.65V ≤3.65V				
Standard charging mode	Charge to 3.65V with a constant power of 448W 448W3.65V				
Standard charging temperature	25°C±2°C				
Absolute charging temperature (cell temperature) ()	0°C~60°C	No matter what charging mode the cell is in,once the cell temperature exceeds the absolute charging temperature range,stop charging.			
Absolute charging voltage	Max 3.8 V	No matter what charging mode the cell is in,once the cell voltage exceeds the absolute charging voltage,stop charging.			

Note:In order to ensure the safe use during the whole life cycle and maximize the service life of the cell,the charging power (rate)must be adjusted according to the SOH (capacity attenuation)of the cell.It should be ensured that the BMS has this function to monitor the actual charging power (and allowable charging power limit),and trigger fault and protection functions when necessary.

4.2.2 Other Charging Modes

4.2.2.1 Continuous charging modes



Table 9 Continuous charging modes (unit:P-Rate)

Model	LF280K	Specification No				PBRI-LF280K-D06-01				Version	C
Cell temperature /°C /°C		0	5	10	15	20	25	45	50	55	60
Max charging power (P)	0%~10 0% SOC	0.03	0.12	0.3	0.5	0.8	1.0	0.8	0.5	0.25	0

4.2.2.2 Staged constant power charging modes

Table 10 Staged constant power charging modes (unit:P-Rate)

Cell temperature 1°C /°C		0	5	10	15	20	25	45	50	55	60
Max charging Power (P)	0%~70% SOC	0	0.2	0.4	0.6	1.0	1.0	1.0	0.75	0.5	0
	70%~100% SOC	0	0.1	0.2	0.4	0.6	1.0	0.5	0.25	0.2	0

Note:In order to ensure the safe use of the whole life cycle and maximize the service life of the cell,the charging power (rate)must be adjusted according to the SOH (capacity attenuation)of the cell.It should be ensured that the BMS has this function to monitor the actual charging power (and allowable charging power limit),and trigger fault and protection functions when necessary.

4.2.3 Discharging Mode

Table 11 Discharging mode parameter table

11

Parameters	Product specifications	Conditions
Standard discharging power	0.5P	25°C±2°C
Maximum continuous discharging power	1P	25°C±2°C
Standard discharge mode	Discharge to 2.5V with a constant power of 448W 448W2.5V	
Discharge cut-off voltage	2.5 V	Temperature T>0°C

	2.0 V	Temperature T≤0°C
Standard discharging temperature	25°C±2°C	
Absolute discharging temperature (cell temperature)	-35°C~65°C	No matter what discharging mode the cell is in,once the cell temperature exceeds the absolute discharge temperature range,stop discharging
Absolute discharging voltage	Min 1.8 V	No matter what kind of discharging mode the cell is in once the cell voltage is less than the absolute discharge voltage,stop discharging



4.2.4 Other Discharging Modes

Table 12 Continuous discharge rate (unit:P-Rate)

Cell temperature /°C		-30	-20	-10	-5	0	5	45	50	55	60
Max discharging power (P)	0%~10% SOC	0	0.2	0.4	0.5	0.5	1.0	1.0	0.5	0.5	0

4.3 Safety Limits

4.3.1 Application Conditions

Customer shall ensure strict compliance with the following cell application conditions:

a)Customer shall configure a battery management and monitoring system to strictly monitor,manage and protect each cell.And a battery management archive shall be established to keep all monitoring data of the cells,so as to be a reference for problems tracing and product quality responsibility division. **EVE is not responsible for product quality assurance if no complete monitoring data of the battery system during its service life is provided.**

b)The waterproof and dust proof problems of the cell shall be fully considered in the design of the pack,and the pack must meet the waterproof and dust proof grade stipulated by relevant national standards.EVE is not **responsible for the damage(such as corrosion,rust,etc.)of the cell caused by waterproof and dust proof problems,**

c)It is forbidden to mix different types of cells in the same battery system(or vehicle),other wise,EVE will **not be responsible for the quality assurance.**



Model	LF280K	Specification No.	PBRI-LF280K-D06-01	Version	C
-------	--------	-------------------	--------------------	---------	---

4.3.2 Voltage Limits

Table 13 Safety limit voltage parameters

Items	Categories	Parameters	Protective Actions
Charging Voltage	Charging Ends	3.65 V	When the cell voltage reaches 3.65 V stop charging
	Third	3.7 V	BMS alarms
	Second	3.75 V	Reduce cell charging current or power
	First	3.80 V	Cut off the current,force the cell to stop working and lock the BMS until the technician solves the problem.
Discharging Voltage	Discharging Ends	2.5V(>0°C);2.0 V(≤0°C)	When the cell voltage reaches 2.5 V (0°C)or 2.0 V(≤0°C),stop charging

Model	LF280K	Specification No	PBRI-LF280K-D06-01	Version	C
				V($\leq 0^{\circ}\text{C}$).	
		Third	2.0V($> 0^{\circ}\text{C}$);1.9 V($\leq 0^{\circ}\text{C}$)	BMS alarms BMS	
		Second	1.9V($> 0^{\circ}\text{C}$);1.8 V($\leq 0^{\circ}\text{C}$)	Reduce cell discharging current or power	
		First	1.85V($> 0^{\circ}\text{C}$);1.75 V($\leq 0^{\circ}\text{C}$)	Cut off the current,force the cell to stop working and lock the BMS until the technician solves the problem.	
	BMS protection	Short circuit protection	Short circuit is not allowed	When a short circuit occurs,the cell will be disconnected by the over-current protection device	

Notes :

a)If the cell charging voltage exceeds the cut-off voltage,corresponding protective actions need to be taken.

EVE shall not be responsible for any cell quality issues caused by exceeding the protection voltage.

b)If the cell discharging v oltag e reaches the cut-off voltage,it is necessary to charge as soon as possible to

prevent the battery from being over-discharged.EVE shall not be responsible for any cell quality issues caused by

over-discharge.

4.3.3 Temperature Limits

Table 14 Safety limit temperature parameters

Items	Parameters	Remarks
-------	------------	---------



Model	LF280K	Specification No	PBRI-LF280K-D06-01	Version	C
Recommended Operating Temperature Range	10°C~45°C	Recommended cell using temperature range			
Maximum operating temperature	60°C	If the cell temperature exceeds the maximum operating temperature,the cell power needs to be reduced to 0			
Minimum operating temperature	-30°C	If the cell temperature exceeds the minimum operating temperature,the cell power needs to be reduced to 0.			
Maximum safe temperature	65°C	If the battery temperature exceeds the maximum safe temperature,it will cause irreversible and permanent damage to the battery,and the usershould not use it higher than the maximum safe temperature.			
Minimum safe temperature	-35°C	If the battery temperature exceeds the minimum safe temperature,it will cause irreversible and permanent damage to the battery,and the user should not lower the minimum safe temperature when using it.			

Notes :

- a)Prohibit charging the cell at low temperatures (lower than 0°C)and the minimum safety temperature specified by this specification,otherwise EVE will not be responsible for any quality assurance liability.
- b)The heat dissipation design of pack may effect cell electrical performances,EVE will not be responsible for any liability regarding cell quality issues caused by the heat dissipation design.

Model	LF280K	Specification No	PBRI-LF280K-D06-01	Version	C
-------	--------	------------------	--------------------	---------	---

4.4 Parameters Recommendation for Module Design

4.4.1 Cell Directions

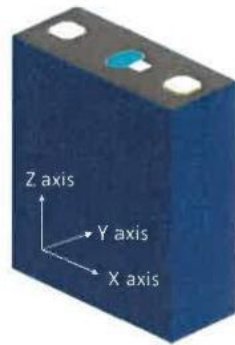

Fig.8 Diagram of LF280K cell direction
8LF280K

4.4.2 Cell Compression Force

When forming modules, a compression force in the direction of vertical thickness is applied to the cells in order to make them better arranged and fixed. If the compression force is too large, the cells may be damaged or even leak. Cell compression force test conditions are as follows:

- Compression area : 173.7 mm×204.6 mm(L×H2)
- Compression speed : 0.02 mm/s
- Compression direction : Y direction Y
- Cell SOC SOC:15 %~40 %

Table 15 Cell compression force limit parameters

Items	Compression Force
Recommended compression force	3000 N~7000 N
Instantaneous maximum compression force	≤10000 N

The compression force of the cell shall be no larger than 10000 N, otherwise the cell may be damaged.

Model	LF280K	Specification No	PBRI-LF280K-D06-01	Version	C
-------	--------	------------------	--------------------	---------	---

4.4.3 Cell Swelling Force

The inherent characteristics such as the rebound of the electrode thickness may lead to cell expansion during use which generates force on the clamp, and the force increases with the attenuation of the cell capacity. The cell swelling force at BOL and EOL(60%SOH) is shown below:

Table 16 Cell swelling force parameters

Swelling Force	BOL	≤3000 N
	70%SOH	≤40000 N
	60%SOH	≤50000 N

Customer shall fully consider the influence of the cell swelling force when designing the module.

4.4.4 Recommended Temperature Collection Points

The recommended temperature collection points are the poles or code when collecting temperature of the cell surface.

4.5 Thermodynamic Parameters

Test method: :

Reference standards: GB/T 10295-2008 、 ASTM E1269-2011

Table 17 Cell thermal conductivity parameters

Mean thermal conductivity	Thermal Conductivity W/(m·K)	
	W/(m·K)	
	X/Z direction	Y direction
	11~13 W/(m·K)	2~3 W/(m·K)
Mean heat capacity	Heat Capacity(kJ/(kg·K))	
	0.9~1.1 kJ/(kg·K)	

Model	LF280K	Specification No	PBRI-LF280K-D06-01	Version	C
-------	--------	------------------	--------------------	---------	---

5 Precautions

5.1 Product End-life Management

The cell life is limited. Customers should establish an effective tracing system to monitor and record the internal resistance and capacity of each cell during its life. The measurement method and calculation method of internal resistance and capacity need to be discussed and agreed between the customer and EVE. When the internal resistance of the cell in use exceeds 150% of the initial internal resistance, or the capacity is less than 60% of nominal capacity, the cell should not be used any more. Violation of this requirement will exempt EVE from its responsibility for product quality assurance in accordance with the product sales agreement and this specification, as well as all **related liabilities such as loss compensation caused thereby.**

5.2 Long-term Storage

After charging, the cell should be used as soon as possible to avoid loss of usable capacity due to self-discharge. If long-term storage is required, adjust the cell SOC to 30%~40%. The recommended storage conditions are: 0°C~25°C, relative humidity ≤ 60%.

The state of charge (SOC, capacity state) of the cell should be kept at 15%~40% during storage. In order to prevent the performance differences after long-term storage (more than three months), perform a standard charge-discharge cycle every 3 months. It is recommended that the storage time after receiving the cells should not exceed half a year to avoid quality problems due to storage overdue.

5.3 Transportation and Handling Requirements

- It is not allowed to ship with inflammable, explosive and corrosive articles in the same vehicle during transportation, and stacking is prohibited during large package transportation; The product shall not be exposed to rain, snow and other liquid substances without any protection, or suffer mechanical damage;

Model	LF280K	Specification No.	PBRI-LF280K-D06-01	Version	C
-------	--------	-------------------	--------------------	---------	---

- While handling, lift trucks or special tools shall be used to load and unload products; Handle with care, Do not throw or squeeze, which may cause cell damage or personal injury. It is strictly prohibited to put cells together with corrosive substances such as acid and alkali.

5.4 Operation Precautions

- It is strictly forbidden to immerse the cell in water. When it is not in use, it should be placed in a cool and dry environment.
- Do not over-charge the cell. Otherwise, cell overheating and fire may occur. During cell installation and use, hardware and software must be protected against multiple over-charge failures. See 4.3 of this specification for the minimum requirements of protection.
- It's necessary to set a reasonable charging time limit, otherwise, the cell may overheat, resulting in thermal runaway or fire. BMS management failure of this kind shall be considered during module design.
- If improper charge termination occurs, the root reasons shall be found and resolved before reuse to avoid negative effects on electrical and safety performances.
- It is forbidden to over-discharge. During the normal use of the cell, charge the cell regularly to keep the voltage above 2.8 V so as to avoid over-discharge.
- It is forbidden to use or place the cell at a high temperature environment. Otherwise, cell overheat, if unclean failure or life shorten may occur.
- The temperature of the cell shall not exceed 65°C in any normal use, otherwise the BMS must shut down the cell and stop cell operation.
- Please use a special charger for lithium-ion batteries when charging.



Model	LF280K	Specification No	PBRI-LF280K-D06-01	Version	C
-------	--------	------------------	--------------------	---------	---

- During use, please connect the positive and the negative of the cell strictly according to the labels and instructions, and reverse charging is forbidden.
- It is forbidden to use metal to directly connect the positive and the negative of the cell to short-circuit. Otherwise, strong current and high temperature may cause personal injury or fire.
- It is forbidden to transport or store the cell with metal, such as hairpins, necklaces, etc.
- It is forbidden to knock, throw, step on or bend the cell.
- It is forbidden to directly weld the cell.
- It is forbidden to directly pierce the cell with nails or other sharp objects.
- Prevent the cell from mechanical shock, collision and pressure impact. Otherwise, the cell may be short-circuited internally, resulting in high temperature and fire.
- It is forbidden to use it in places with strong static electricity and strong magnetic fields; otherwise cell safety protection devices may be damaged and cause safety hazards.
- Customer shall securely fix the cell to a solid surface and bind the power cord in a proper place to avoid arcing and sparks caused by friction.
- It is forbidden to use plastic for cell encapsulation and electrical connection. Improper electrical connection may cause overheating during cell use.
- If the cell leaks and the electrolyte spills onto the skin or clothes, immediately wash the affected area with running water. If the cell leaks and the electrolyte enters the eyes, mouth, nose and other open parts of the human body, immediately wash with plenty of water and seek medical treatment immediately, otherwise serious injuries will be caused to the human body. No person or animal is allowed to swallow any part of the cell or any substance contained in the cell.
- If the cell emits peculiar smell, heat, discoloration, deformation, or any abnormality during use, storage, or charging, immediately remove the cell from the device or charger and stop using it.
- It is prohibited to disassemble the product without the written consent of EVE.

Model	LF280K	Specification No	PBRI-LF280K-D06-01	Version	C
-------	--------	------------------	--------------------	---------	---

5.5 Confidentiality agreement

The customer shall keep the cooperation content highly confidential. Without the permission of EVE, the customer shall not disclose any content of the technical agreement to a third party. Otherwise, the customer will be held responsible according to relevant laws.

5.6 Risk Waring

5.6.1 Warning Declaration

Warning

The cell has potential hazards. Please take proper precautions when operating and maintaining the cell!

The cell must be operated with proper tools and protective equipment.

Cell maintenance must be performed by professionals with cell expertise and safety training.

Failure to comply with these warnings may result in multiple disasters.

Model	LF280K	Specification No	PBRI-LF280K-D06-01	Version	C
-------	--------	------------------	--------------------	---------	---

5.6.2 Types of Dangerous

Customer must be aware of the following potential hazards in the use and operation of cells:

- a) There is a risk from electric shocks electronic arcs during operation.
- b) There is a risk from the electrolyte or other chemicals.

Proper operation methods and protective equipment shall be selected to avoid accidental short circuit, leading to

electric arcs, explosion or thermal runaway.

5.7 Disclaimer

If the product demand party or user does not use the product in accordance with the provisions of this specification, EVE will no longer take any relevant responsibility such as product quality assurance liability and loss compensation caused thereby. In case of any negative impact on EVE's reputation due to the above-mentioned actions, EVE reserves the right to investigate the legal liability of the product demand party.

6 Others

6.1 Rights and Obligations of EVE EVE

- EVE shall inspect according to the inspection standards in the protocol signed with the customer, and the products provided shall meet the requirements of various parameters in the protocol;
- EVE shall provide customer with stable and reliable products confirmed by both parties;
- EVE is obliged to provide high-quality services for its products, and the service standards shall be in accordance with the standards promised by EVE;
- EVE shall provide timely technical support and service in case of any problem or failure during the use and maintenance of system products by customer.

6.2 Rights and Obligations of Customer

- Customer must conduct production in strict accordance with the technical data provided by EVE, and strictly implement the cell prevention measures, safety limits and cell operation instructions in the technical data provided
- Customer has the obligation to ensure the safety of products by EVE and shall take corresponding fire prevention, waterproof and other measures.
- Customer has the obligation to make fair and detailed use records and monitoring data of product operation for EVE's products, which can be used as a reference for the division of product quality responsibilities. If there is no complete monitoring data within the service life of the battery system, EVE shall not be responsible for product quality assurance.
- Customer has the obligation to notify EVE's personnel to be present and be informed of the actual situation when products of EVE operate abnormally.

Model	LF280K	Specification No	PBRI-LF280K-D06-01	Version	C
-------	--------	------------------	--------------------	---------	---

- In the process of product manufacturing, customer shall take all corresponding responsibilities for the problems or accidents caused by the operation in violation of the safety rules, the use beyond the conditions specified in this technical agreement, or the combination of the product and the circuit (not the qualify defects of the product itself).
- Any matter not mentioned in this specification must be negotiated and determined by both parties.

6.3 Language Conflict Clause

- This specification is written in both Chinese and English. In case of any conflict between the Chinese and English agreements, the Chinese version shall prevail.

Appendix: Cell Drawing of LF280K : LF280K

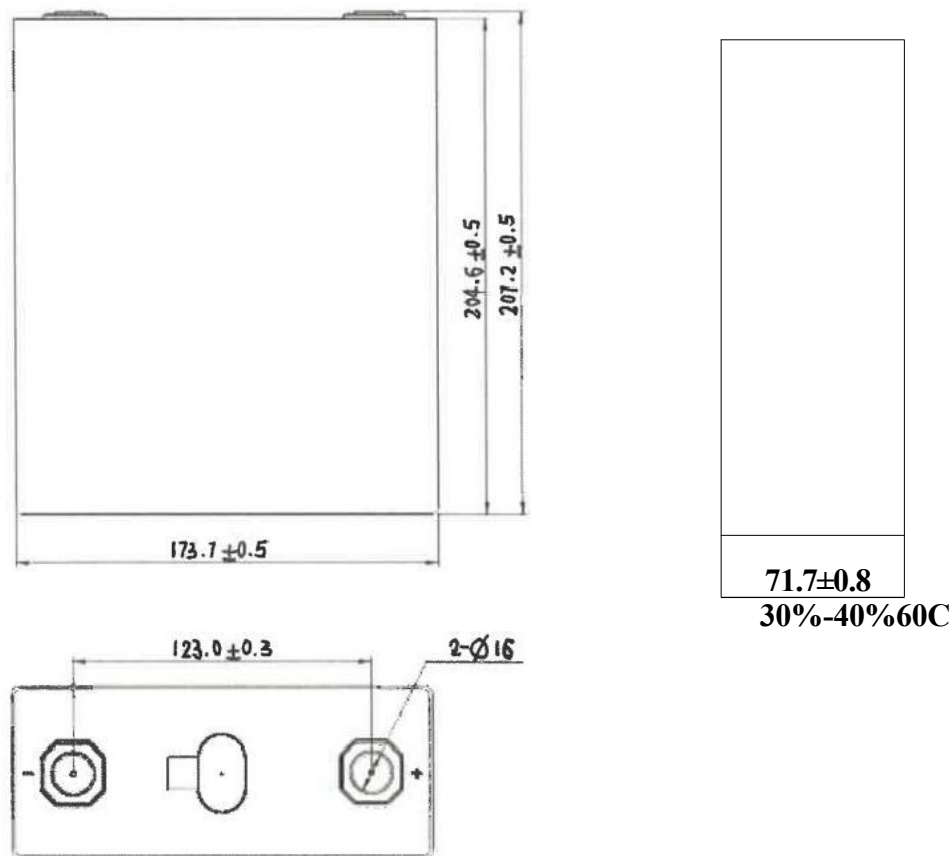

Fig.9 Diagram of cell size and appearance